

Answer ALL questions in the spaces provided.

1 A practical physics textbook states that “measurements may give a precise value for the quantity being determined but this may not necessarily be an accurate value”.

(a) Describe what physicists mean by the terms accuracy and precision.

(2)

.....

.....

.....

.....

.....

.....

(b) The temperature of the air in a room is measured using a mercury-in-glass thermometer.

Describe how the value for the temperature may be precise but not accurate.

(2)

.....

.....

.....

.....

.....

.....

(Total for Question 1 = 4 marks)

DO NOT WRITE IN THIS AREA

DO NOT WRITE IN THIS AREA

DO NOT WRITE IN THIS AREA



3 A student was investigating the forces involved in circular motion.

He placed a small coin on a horizontal turntable as shown. The turntable was connected to a driver unit so that it could be rotated at a constant rate.

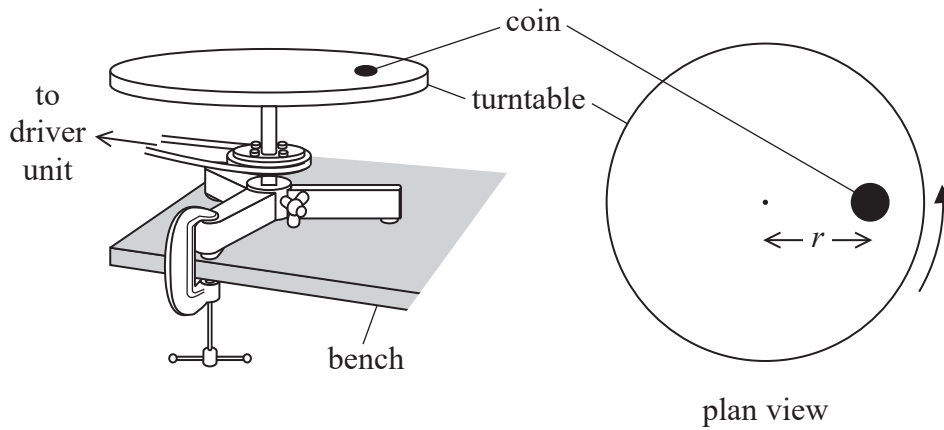

(a) The student measured the distance r between the centre of the turntable and the centre of the coin, with a metre rule as shown.

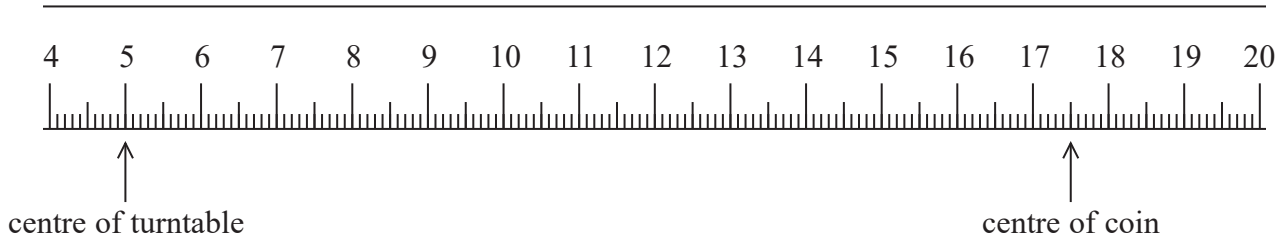

Explain why the percentage uncertainty in the value of r is about 1%.
Your answer should include a calculation.

(3)

.....

.....

.....

.....

.....

.....

DO NOT WRITE IN THIS AREA

DO NOT WRITE IN THIS AREA

DO NOT WRITE IN THIS AREA



- (b) The student switched on the driver unit and increased the rate of rotation until the coin slid off the turntable. He read the angular velocity ω of the turntable from a digital display on the driver unit. He then replaced the coin in the original position on the turntable and repeated the procedure.

His results are shown.

$\omega / \text{rad s}^{-1}$				
0.125	0.112	0.118	0.123	0.116

- (i) The student used the results to calculate a mean value of ω .

State the purpose of calculating a mean.

(1)

- (ii) Calculate the percentage uncertainty in the mean value of ω .

(3)

Percentage uncertainty =

- (iii) The student used ω and r to calculate the centripetal acceleration of the coin at the instant it started to slide.

Calculate the percentage uncertainty in this centripetal acceleration.

(3)

Percentage uncertainty =



(c) The student repeated the procedure with different values of r .

Explain how the value of ω at which the coin started to slide varied as r increased.

(3)

.....

.....

.....

.....

.....

.....

.....

(Total for Question 3 = 13 marks)

DO NOT WRITE IN THIS AREA

DO NOT WRITE IN THIS AREA

DO NOT WRITE IN THIS AREA



- 6 The Enterprise is an amusement park ride. Riders sit in cars that are made to rotate in a vertical circle.

The ride starts by moving in a horizontal circle. The speed of rotation increases, and the frame tilts until the ride is rotating vertically as shown.



The photograph below shows riders at the top of the vertical circle. The riders are in contact with their seats at all times during the ride.



The diagram shows the weight W of a rider and the push P from the seat on the rider at the top and bottom of the circular path.

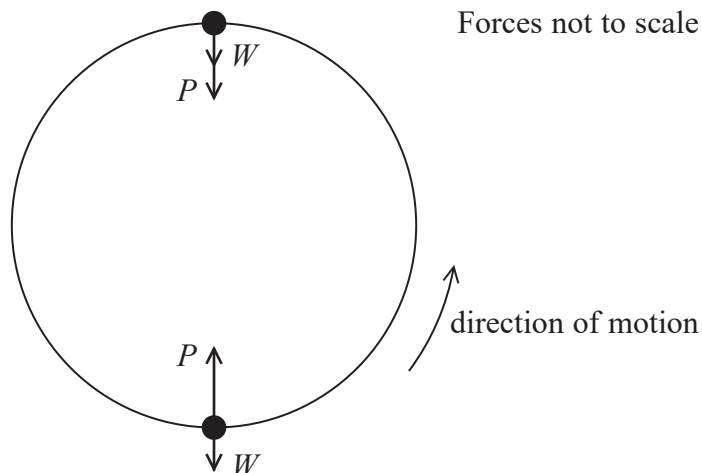

DO NOT WRITE IN THIS AREA

DO NOT WRITE IN THIS AREA

DO NOT WRITE IN THIS AREA



DO NOT WRITE IN THIS AREA

DO NOT WRITE IN THIS AREA

DO NOT WRITE IN THIS AREA

*(a) The rider moves from the bottom to the top of the circular path.

Explain how the apparent weight experienced by the rider would change.

(6)

.....

.....

.....

.....

.....

.....

.....

.....

.....

.....

.....

.....

.....

.....

.....

.....

.....

.....

.....

.....

.....

.....

.....

(b) On the website of the amusement park it states

“The ride is perfectly safe without the need for safety harnesses for the riders.
Centrifugal force ensures that the riders remain in their seats at all stages in the ride.”

Assess the validity of this statement.

(4)

.....

.....

.....

.....

.....

.....

.....

.....

.....

.....

.....

.....

.....

.....

.....

.....

.....

.....

.....

.....

.....

.....

(Total for Question 6 = 10 marks)

